

# Geesink Norba G-28H25

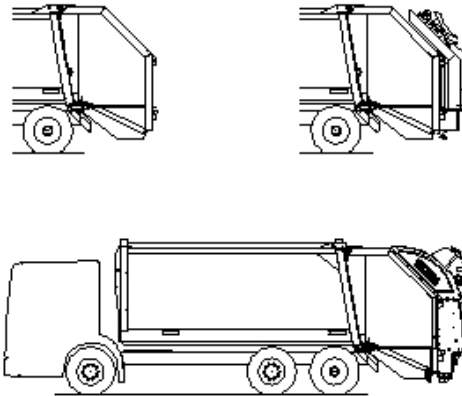

The GPMIII Wide series of rear-loading frontline vehicles for both trade and domestic collections, range from 14m<sup>3</sup> to nearly 27m<sup>3</sup> in size.

The bodies - either low or high - are smooth-sided with the hopper, tailgate and compaction and ejection plates designed for easy maintenance.

The Smartpack System TM controls bin lift speeds and other functions independently of the loading weight. Automatic sensing of how much pressure is needed helps fuel economy.

They can operate with open back or with an extensive range of Geesink Norba's lifts including Trade, Split, Industrial GEC, Industrial GHC, Industrial Skips, Industrial Skip Trade or with third party lifts. On continental Europe they are also used with Geesink Norba's Crane, Crane Trade and Crane Split lifts. In-cab controls allow adjustment of operational variables including compaction parameters.

The vehicle is available with the super-green Plug-in Electric functionality. The market-leading Eurovim telemetrics system is built in and the Eurovim Plus advanced system can be added.

For further information contact us on 01443 220633 or 07801 809240.

To arrange a demonstration of this vehicle contact us on 01443 220635.

To get a quote on the cost of this vehicle contact us on 01443 220632.



## GEESINKNORBA

Llantrisant Business Park Llantrisant Pontyclun CF72 8XZ

Tel: +44(0)1443 222301 Fax: +44(0)1443 220 637

[www.geesinknorba.com](http://www.geesinknorba.com) [sales.uk@geesinknorba.com](mailto:sales.uk@geesinknorba.com)

## G-28H25

Series	G-Series
Product name	G-28H25
Formerly known as	GPM III 28H22
Uses	Rear Loader
Body fabrication	Fully Welded
Body access door	Standard right hand side
Body construction	Smooth sided
Height	from bottom of the bottom of the body to the top, 2405 mm
Width	the widest point of the body, 2500 mm
Length	Body, 6375 mm
Body capacity	26.87 m3
Blade back off relief valve	Yes
Cycle time packing mechanism	22 sec
Floor and Side Walls Construction	High Tensile
Automatic Discharge Clearing Cycle	Yes
Packing mechanism in matt black	Colour coding chargeable extra, Yes
Automatic Integral Tailgate Locks	Adjustable, Yes
Maintenance of Carriage Plate	Easy maintenance without removing carriage plate
Slide Blocks	Nylon 66
Ejector Blade in matt black	Yes
Double Acting Ejector Cylinder	Yes
Maintenance of Ejector Blade	Easy maintenance without removing ejector blade
Pump	Double Pump or Variable Flow Pump (optional)
Sensors	Load sense
Hydraulic tank volume	185 litres
Pressure control valves	Yes
Main relief valve setting	255 bar
Adjustable Counter Pressure Operated from Display in Chassis Cabin Control Box	In steps of 10%

## G-28H25

User programmable pressure settings	In Cabin Control Box
Fault diagnosis remote	With optional Modem
Bin Lift Counter on Integrated Models	In Cabin Control Box
Controls	Euro Vim Can Bus System
Press Cycle Counter	In Cabin Control Box
Fault diagnosis	In Cabin Control Box
Operating Hour Counter	In Cabin Control Box
Lubrication	Manual or central automatic (optional)
Compliance	EN1501
Manuals/training	Scheduled operator training available. User and Service manual supplied
Warranty	1 year standard parts and labour warranty with optional extension packages
Geesinknorba Open Back	Yes
Geesinknorba 3rd Party	Yes
Geesinknorba Trade	Yes
Geesinknorba Split	Yes
Geesinknorba Industrial GEC	Yes
Geesinknorba Industrial GHC	Yes
Geesinknorba Industrial Skip	Yes
Geesinknorba Industrial Skip Trade	Yes
Geesinknorba Crane	Yes
Geesinknorba Crane Trade	Yes
Geesinknorba Crane Split	Yes